

Replacement Boiler Tubes & Pressure Parts for KE's Keystone, HRSG & Solid Fuel Fired Boilers

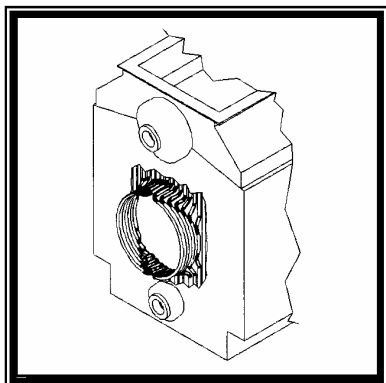

KE's Water Cooled Burner Throat Tubes for Keystone Package Boiler

KE offers replacement boiler tubes and pressure components that are manufactured to our original detailed designs and in strict accordance with ASME Code. In addition to direct replacement parts for all KE (Zurn and Erie City Iron Works) boilers, we can also provide design enhancements that are tailored to meet unique operational needs and conditions. Such enhancements may include welded tube walls to replace refractory walls, adding heat transfer surface, or redesigning tubes to permit access for doors, observation ports, or soot blowers.

Features

- 4 Tube and pressure parts are manufactured in strict compliance with ASME Code and our OEM Quality Control standards.
- 4 Exact tube and pressure part replacement dimensions held to assure original boiler construction.
- 4 Revisions and redesigned tubes available.
- 4 Our tube and parts carry a one year material and workmanship warranty.

Application

All replacement tubes and pressure components required by your KE boiler should only be replaced with genuine KE products. These products, manufactured per our original detailed drawings, will help your boiler perform up to its original intended service.

Benefits

- 4 Original replacement parts eliminate risky and time consuming field estimates and templating.
- 4 Exact replacement parts enhance ease of installation and fit the first time.
- 4 True tangent wall tube design for a "gas-tight" fit is achievable only with our special bending dies.
- 4 Special modifications to help improve boiler operations may be made.

For more information, please contact:

Keystone Energy A/S
Div of Erie Power Technologies, Inc.
5300 Knowledge Parkway
Erie, PA 16510-4660

Phone 814.452.6421
Fax 814.897.1089

www.keystone-energy.com

24-Hour Availability
1-800-322-5995