

Self-Supported Steam Cooled Superheater Elements for Keystone Package Boilers

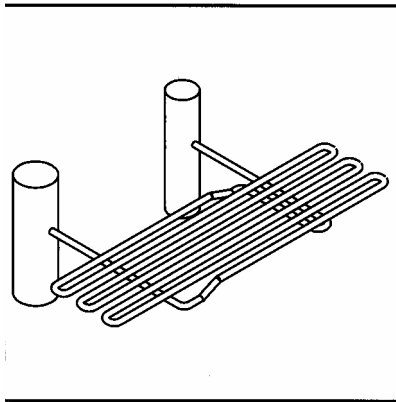

Self-Supporting Steam Cooled Superheater Element

Keystone Energy's replacement superheater elements are now available in a self-supporting steam cooled design for our Keystone Package Boilers. This design provides improved support and flow characteristics. These elements replace those currently supported by non-cooled lugs, tile, and/or individual steam cooled support tubes.

Features

- 4 Unique one-piece element design
- 4 Stainless steel expansion clips replace rigid bar-type lugs
- 4 Existing headers may be reused for units with 2" tubes on 4" spacing
- 4 Revised assembly drawings and installation procedure

Benefits

- 4 Element sagging is eliminated with proper operation
- 4 Enhanced flow distribution and performance predictability provide longer element life
- 4 One-piece design minimizes installation costs
- 4 Stainless steel expansion clips lessen the opportunity for tube failures

Application

Keystone users with sagging superheater elements and/or temperature control problems should consider installing this design.

For more information, please contact:

Keystone Energy A/S
Div of Erie Power Technologies, Inc.
5300 Knowledge Parkway
Erie, PA 16510-4660

Phone 814.452.6421
Fax 814.897.1089

www.keystone-energy.com

24-Hour Availability
1-800-322-5995