

Low NOx Burner System

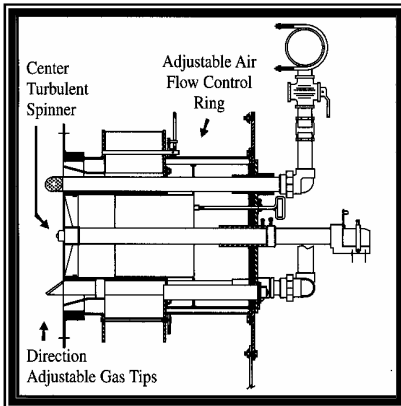

KE Low NOx Burner

Keystone Energy's Low NOx burner and Low NOx retrofit kits are available for existing Keystone Energy burner equipment firing natural gas and No. 2 oil fuel. The new unit and retrofit kits have been successfully demonstrated on a wide range of Keystone package units. Reductions in NOx emission levels have been successful in achieving compliance with current and pending emission regulations.

Features

- 4 Manually adjustable airflow control ring to separate the combustion air into two pressure zones (central and peripheral) to induce and optimize staged combustion.
- 4 The air flow control ring forms a high pressure outer cooling ring mixture of air and fuel that is recirculated back into the low pressure flame center to cool flame temperature and limit NOx formation.
- 4 Center turbulent spinner designed to evenly distribute low-pressure central airflow to enhance fuel and air mixture.
- 4 The center turbulent spinner further reduces NOx formation and high flame temperatures by limiting the oxygen available in the low-pressure flame center that can combine with fuel bound nitrogen.
- 4 Direction-adjustable gas tips to control flame length, shape, and stability to enhance burner firing efficiency.
- 4 IFGR/FFGR can be utilized to further enhance NOx reduction.
- 4 Hinged burner front plate allowing access to the internal burner components and to the boiler's furnace through the burner front. Keystone Energy is the only major burner manufacturer that offers this feature.

Benefits

- 4 NOx formation is substantially reduced
- 4 Low capital expenditure by retrofitting to existing windbox, FD fan, front wall refractory and fuel piping
- 4 Fast delivery; minimum installation time

Application

Keystone Energy's Low NOx burner can be furnished on all of our existing boiler installations as well as applied to other manufacturer's equipment.

For more information,
please contact:

Keystone Energy A/S
Div of Erie Power Technologies, Inc.
5300 Knowledge Parkway
Erie, PA 16510-4660

Phone 814.452.6421
Fax 814.897.1089

www.keystone-energy.com

24-Hour Availability
1-800-322-5995